

VÝMENNÉ ELEKTRODY

OTVOR V PLECHU ØD	SW 36	OTVOR V PLECHU ØD	SW 36
13.0	1111-ZK-20192	14.3	1111-ZK-20205
13.1	1111-ZK-20193	14.4	1111-ZK-20206
13.2	1111-ZK-20194	14.5	1111-ZK-20207
13.3	1111-ZK-20195	14.6	1111-ZK-20208
13.4	1111-ZK-20196	14.7	1111-ZK-20209
13.5	1111-ZK-20197	14.8	1111-ZK-20210
13.6	1111-ZK-20198	14.9	1111-ZK-20211
13.7	1111-ZK-20199	15.0	1111-ZK-20212
13.8	1111-ZK-20200	15.1	1111-ZK-20213
13.9	1111-ZK-20201	15.2	1111-ZK-20214
14.0	1111-ZK-20202	15.3	1111-ZK-20215
14.1	1111-ZK-20203	15.4	1111-ZK-20216
14.2	1111-ZK-20204	15.5	1111-ZK-20217

KERAMICKÉ KOLÍKY CERAZUR

OTVOR V PLECHU ØD	KRÁTKY	DLHÝ	S GOLIEROM
13.0	8228-ZK-11100	8228-ZK-10100	8228-ZK-10400
13.1	8228-ZK-11101	8228-ZK-10101	8228-ZK-10401
13.2	8228-ZK-11102	8228-ZK-10102	8228-ZK-10402
13.3	8228-ZK-11103	8228-ZK-10103	8228-ZK-10403
13.4	8228-ZK-11104	8228-ZK-10104	8228-ZK-10404
13.5	8228-ZK-11105	8228-ZK-10105	8228-ZK-10405
13.6	8228-ZK-11106	8228-ZK-10106	8228-ZK-10406
13.7	8228-ZK-11107	8228-ZK-10107	8228-ZK-10407
13.8	8228-ZK-11108	8228-ZK-10108	8228-ZK-10408
13.9	8228-ZK-11109	8228-ZK-10109	8228-ZK-10409
14.0	8228-ZK-11110	8228-ZK-10110	8228-ZK-10410
14.1	8228-ZK-11111	8228-ZK-10111	8228-ZK-10411
14.2	8228-ZK-11112	8228-ZK-10112	8228-ZK-10412
14.3	8228-ZK-11113	8228-ZK-10113	8228-ZK-10413
14.4	8228-ZK-11114	8228-ZK-10114	8228-ZK-10414
14.5	8228-ZK-11115	8228-ZK-10115	8228-ZK-10415
14.6	8228-ZK-11116	8228-ZK-10116	8228-ZK-10416
14.7	8228-ZK-11117	8228-ZK-10117	8228-ZK-10417
14.8	8228-ZK-11118	8228-ZK-10118	8228-ZK-10418
14.9	8228-ZK-11119	8228-ZK-10119	8228-ZK-10419
15.0	8228-ZK-11120	8228-ZK-10120	8228-ZK-10420



Na objednávku dodávame aj kolíky z materiálu Volcera.  
Kód produktu: „8440-ZK-xxxx“ („xxxx“ je posledné päťčísle v tabuľke, napr. pre Ø13.0 je kód 8440-ZK-11100)

# ZOSTAVY PRE NAVAROVANIE MATÍC M12 CHLADENÉ VODOU

Pro Spot

## DRŽIAKY ELEKTRÓD

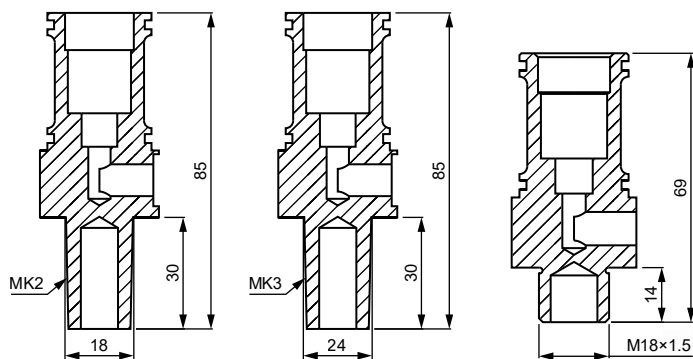

VEĽKOSŤ MATICE	KUŽEL MK2	KUŽEL MK3	ZÁVIT M18x1.5
M12	1111-ZK-20544	1111-ZK-20545	1111-ZK-20563

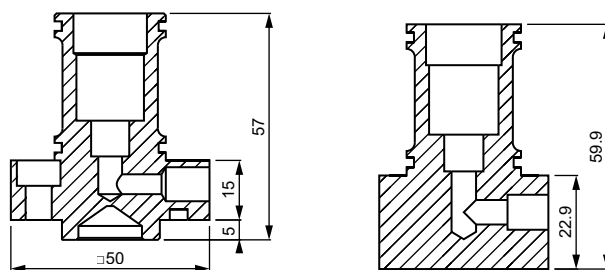

VEĽKOSŤ MATICE	R-TYP	C-TYP
M12	1111-ZK-10644	1111-ZK-10663

## CHLADIACI KRÚŽOK

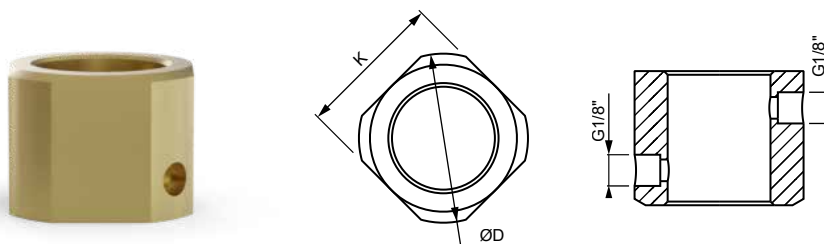

VEĽKOSŤ MATICE	OZNAČENIE	$\varnothing D$	K
M10, M12	1113-ZK-19767	52	46
C-typ M10 až M12	1113-ZK-19769	52	46

## PRÍSLUŠENSTVO K DRŽIAKOM ELEKTRÓD

PRUŽINA



O-KRÚŽOK



RÝCHLOSPOJKA



DĹŽKA DRŽIAKA	OZNAČENIE
od 40 mm	1112-ZK-12207

TYP DRŽIAKA	OZNAČENIE
$\varnothing 34$	1123-ZK-26187

—	OZNAČENIE
prívod stlačeného vzduchu G1/8"- $\varnothing 6$	1116-ZK-12353

ADVANCED CERAMIC SOLUTIONS  
**DOCCERAM**<sup>®</sup>

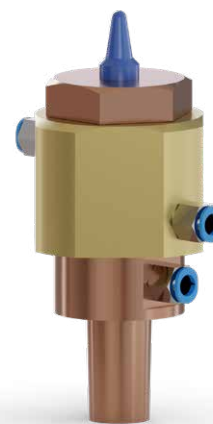

VÝMENNÁ  
ELEKTRÓDA

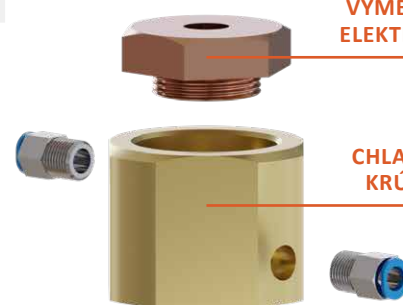

CHLADIACI  
KRÚŽOK

POLOHOVACÍ  
KOLÍK



PRUŽINA



DRŽIAK  
ELEKTRÓDY S  
O-KRÚŽKAMI



RÝCHLOSPOJKA  
NA STLAČENÝ  
VZDUCH

